

## Current Sensor

---

Product Series: STK-616KMF

Part number: STK-616K-30MFB5  
STK-616K-40MFB3  
STK-616K-65MFB3

Version: Ver 2.6

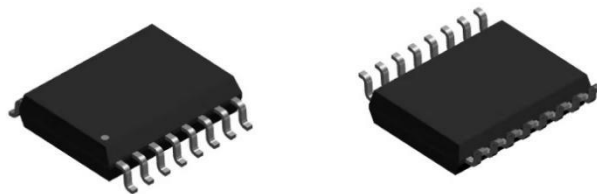

Sinomags Technology Co., Ltd

Web site: [www.sinomags.com](http://www.sinomags.com)

## CONTENT

1.	Description .....	2
2.	Part number definition .....	3
3.	Temperature vs Current.....	4
4.	Electrical data STK-616K-XXMFB3 .....	5
5.	Dimension & Pin definitions.....	6
6.	Pin definitions .....	7
7.	PCB layout recommendation .....	7
8.	Frequency bandwidth of STK-616K-XXMFB3.....	8
9.	Step response time of STK-616K-XXMFB3.....	8
10.	The delay time of Triangular Wave. ....	9
11.	Typical Application of STK-616KMF .....	10
12.	Examples of OCD function .....	10
13.	General information on OCD.....	11
14.	PACKAGE MATERIALS INFORMATION .....	13

## 1. Description

The STK-616KM series current sensor is based on TMR (tunnel magneto resistance) technology and open-loop design. It is suitable for DC, AC pulsed and any kind of irregular current measurement under the isolated conditions.

- The product is packaged in standard SOIC16 form.
- AEC-Q100, automotive qualified.

### Typical applications

- AC Variable speed drives
- Inverter
- Electric welder power supply
- Switched model power supplies (SMPS)

### General parameter

Parameter	Symbol	Unit	Value
Working temperature	T_A	°C	-40 ~ 125
Storage temperature	T_stg	°C	-40 ~ 125
Mass	m	g	0.5

### Absolute maximum rating

Parameter	Symbol	Unit	Value
Supply voltage	V <sub>cc</sub>	V	6
ESD rating (HBM)	U_ESD	kV	4
Junction temperature	T_J	°C	150

Remark: the unrecoverable damage may occur when the product works on the conditions over the absolute maximum ratings. Long-time working on the absolute maximum ratings may cause the degradation on performance and reliability.

### Isolation parameter

Parameter	Symbol	Unit	Value	Comment
RMS voltage for AC test 50Hz/1 min	U <sub>d</sub>	kV	3.6	
Impulse withstand voltage 1.2/50μs	Ū <sub>w</sub>	kV	10	
Clearance distance (pri. -sec)	d <sub>Cl</sub>	mm	7.5	Determined by customer's layout
Creepage distance (pri. -sec)	d <sub>Cp</sub>	mm	7.5	

### Measuring current table

Product	Optimized Range I <sub>pn</sub> (A)	Sensitivity, (mV/A)	V <sub>cc</sub> (V)	T(°C)
STK-616K-40MFB3-1-1.65-E-2-C	±40A	33	3.3V	-40 ~ 125
STK-616K-40MFB3-1-1.65-E-1-Z	±40A	33	3.3V	-40 ~ 125
STK-616K-40MFB3-1-1.65-X-X-X	±40A	33	3.3V	-40 ~ 125
STK-616K-40MFB3-1-1.65-E-2-Z	±40A	33	3.3V	-40 ~ 125
STK-616K-40MFB5-1-2.5-E-2-Z	±40A	50	5V	-40 ~ 125
STK-616K-65MFB3-1-1.65-E-2-C	±65A	20.3	3.3V	-40 ~ 125

STK-616K-65MFB3-1-1.65-E-1-Z	±65A	20.3	3.3V	-40 ~ 125
STK-616K-65MFB3-1-1.65-E-2-Z	±65A	20.3	3.3V	-40 ~ 125
STK-616K-30MFB5-1-2.5-E-1-Z	±30A	66.6	5V	-40 ~ 125
STK-616K-30MFB5-1-2.5-E-2-Z	±30A	66.6	5V	-40 ~ 125

## 2. Part number definition

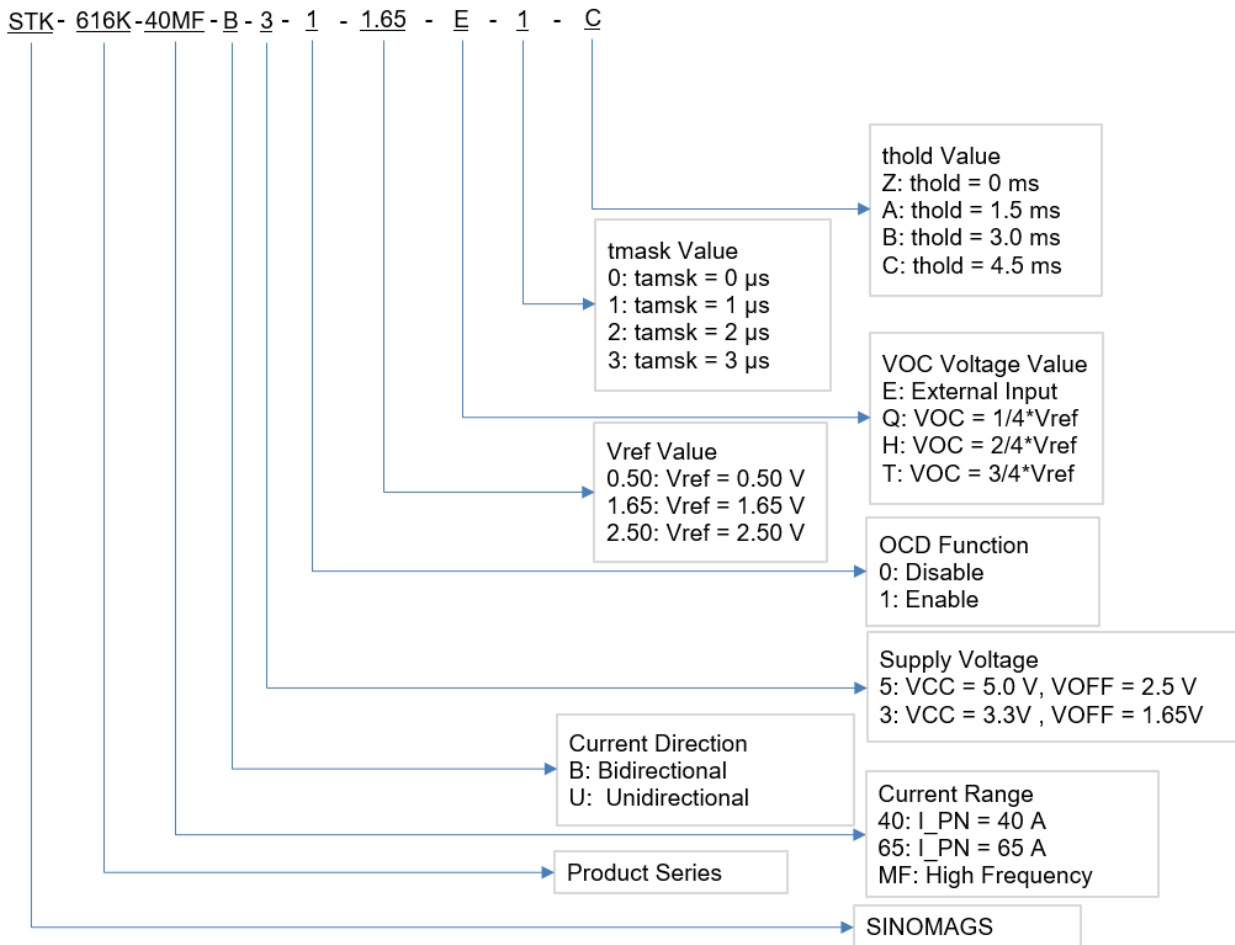

### 3. Temperature vs Current

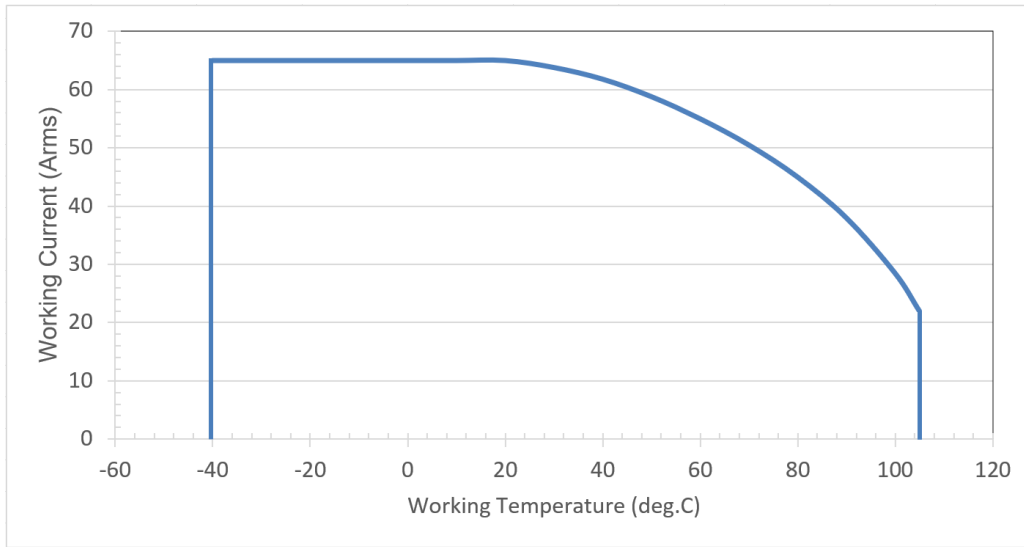

## 4. Electrical data STK-616K-XXMFB3

 Condition:  $T_A = 25^{\circ}\text{C}$ ,  $V_{CC} = 3.3\text{ V}$ 

Parameter	Symbol	Unit	Min	Typ	Max	Comment
General parameters						
Primary nominal current	I <sub>pn</sub>	A	-40		40	STK-616K-40MFB3
			-65		65	STK-616K-65MFB3
Supply voltage	V <sub>CC</sub>	V	3.15	3.3	3.45	
Current consumption	I <sub>CC</sub>	mA		7	12	
Primary Conductor Resistance	R <sub>IP</sub>	mΩ		0.85		
Quiescent voltage	V <sub>off</sub>	V	1.6	1.65	1.7	
Internal output resistance	R <sub>out</sub>	Ω	1		30	
Theoretical gain	G <sub>th</sub>	mV/A		33		STK-616K-40MFB3
				20.3		STK-616K-65MFB3
OCD function (if applicable)						
OCD range	V <sub>OC</sub>	V	0.3		1.6	
FAULT error		%		5%		% of OCD
OCD Hysteresis	I <sub>HYS</sub>	%		10%		% of OCD
OCD Fault Mask	t <sub>mask</sub>	μs		1		0, 1, 2, 3 μs
OCD Fault Mask error	T <sub>mask_error</sub>	ns		125		
OCD Fault Hold Time	t <sub>hold</sub>	ms		4.5		0, 1.5, 3, 4.5 ms
Rated linearity error@25°C	Non-L	%I <sub>pn</sub>		±1.5		±I <sub>pn</sub>
Accuracy performance						
Delay time	t <sub>delay</sub>	μs		0.2		@400 kHz
Step response time	t <sub>res</sub>	μs		0.2		@90% of I <sub>pn</sub> STK-616K-XXMFB3
Frequency bandwidth	BW	MHz		1.5		@-3dB STK-616K-XXMFB3
Output voltage noise	V <sub>noise</sub>	mV <sub>pp</sub>		10		@1.4MHz
Accuracy @ 25°C	X	% I <sub>pn</sub>		±1.5		@ 0.5*I <sub>pn</sub>
Thermal drift of G <sub>th</sub>	Gain <sub>T</sub>	% of G <sub>th</sub>		±1.5		@ -40~105°C
Thermal drift of V <sub>off</sub>	V <sub>off_T</sub>	mV		±15		drift related to the
Total Accuracy	X <sub>TRange</sub>	% of I <sub>pn</sub>		±3		value @25°C

## 5. Dimension & Pin definitions

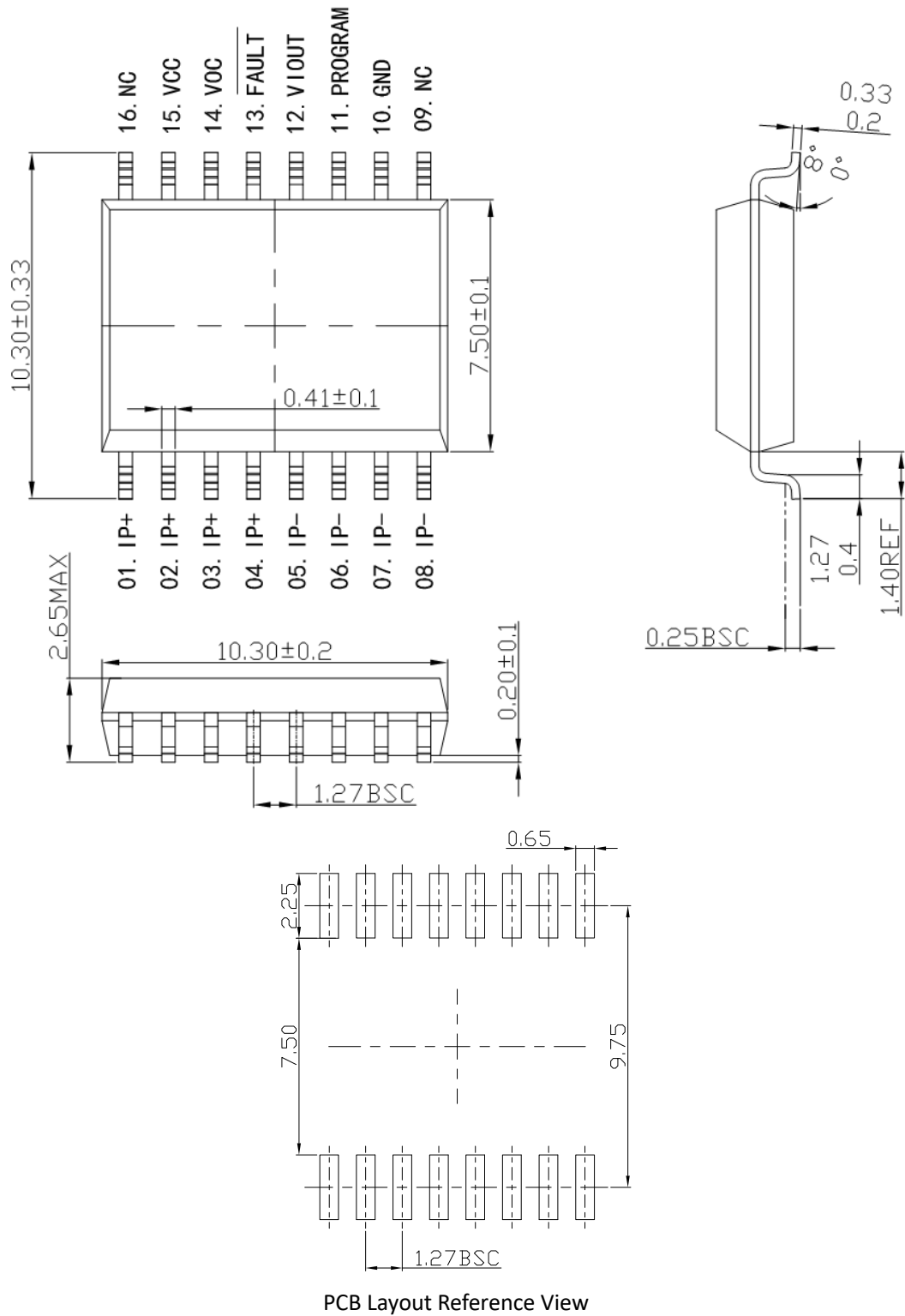

## 6. Pin definitions

PIN	Symbol	Description
1,2,3,4	IP+	Primary conductor pin ( + )
5,6,7,8	IP-	Primary conductor pin ( - )
9	NC	Not connected
10	GND	Ground pin (GND)
11	PROGRAM	Internal use only
12	VIOUT	Sensor output pin
13	FAULT	Over current detection alarm output, the pin is open leakage output。 Normally, the output of fault pin is high level
14	VOCD	Over current detection threshold input pin
15	VCC	Power supply pin
16	NC	Not connected

## 7. PCB layout recommendation

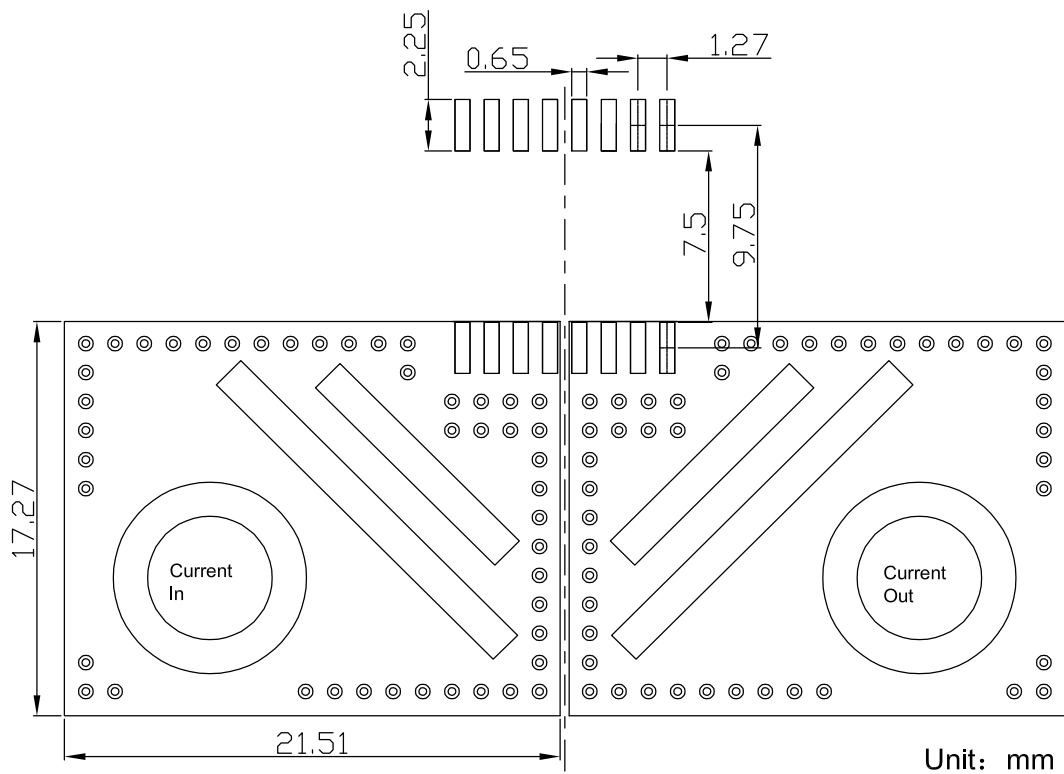



### 8. Frequency bandwidth of STK-616K-XXMFB3

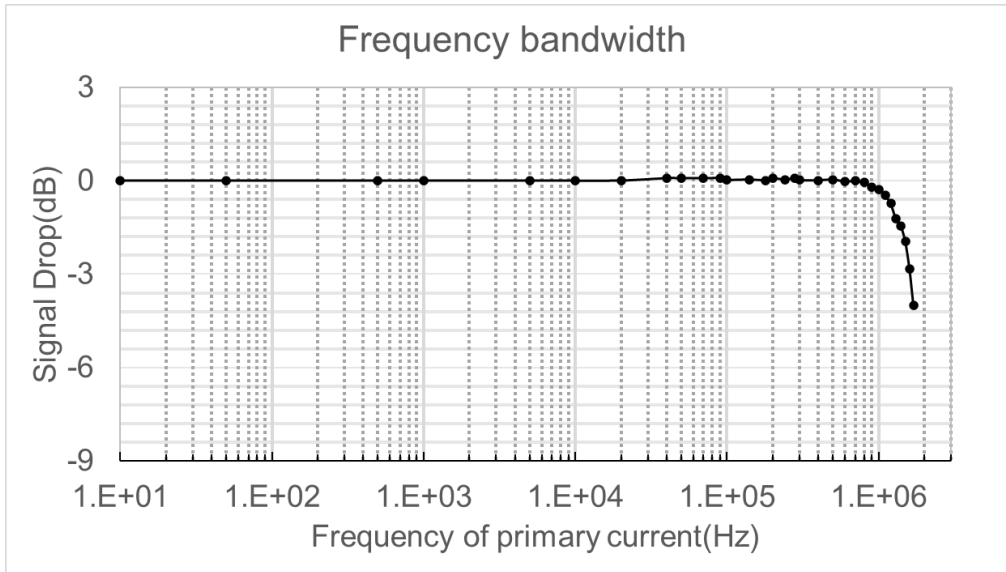

### 9. Step response time of STK-616K-XXMFB3

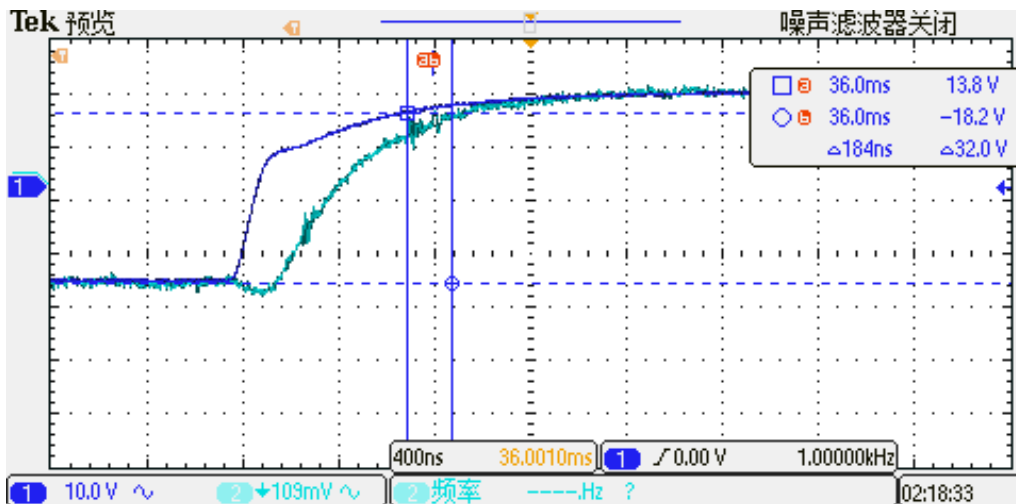

The typical frequency response of STK-616KMF current sensor. The response time from 90% of the primary current to 90% of the secondary output is about 0.2μs.

### 10. The delay time of Triangular Wave.

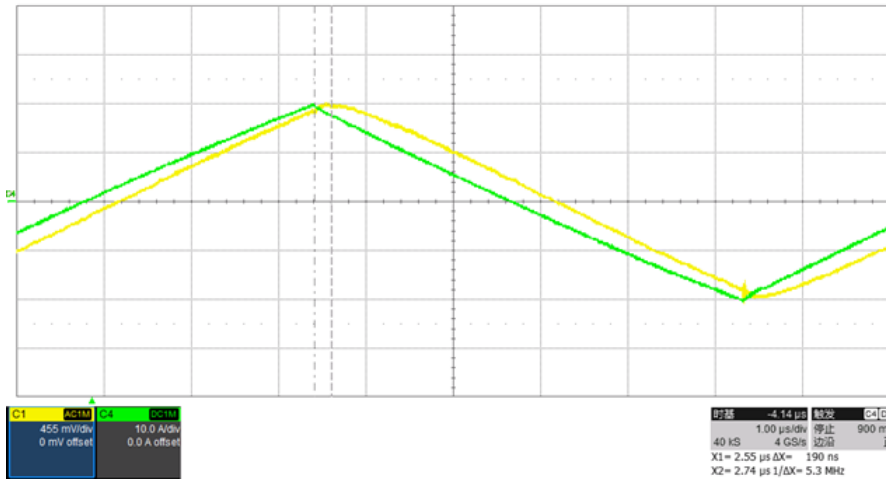

100 kHz Triangular delay---0.2 μ s

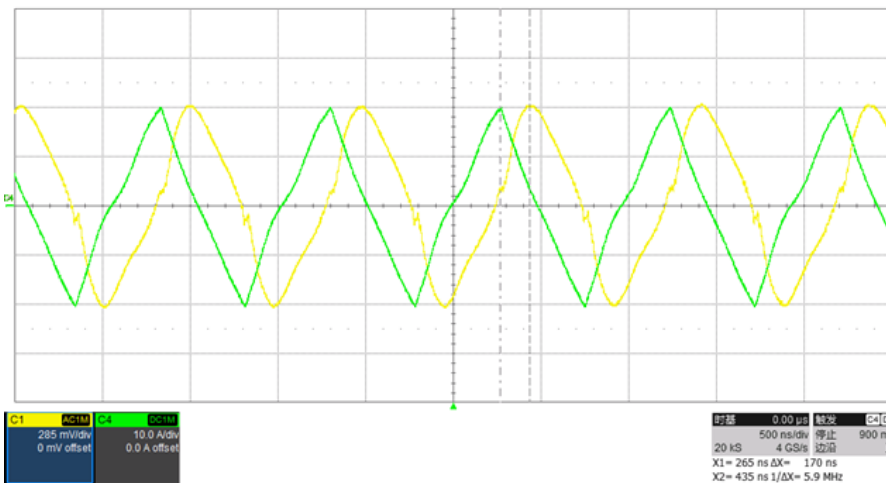

1MHz Triangular delay---0.2 μ s

## 11. Typical Application of STK-616KMF

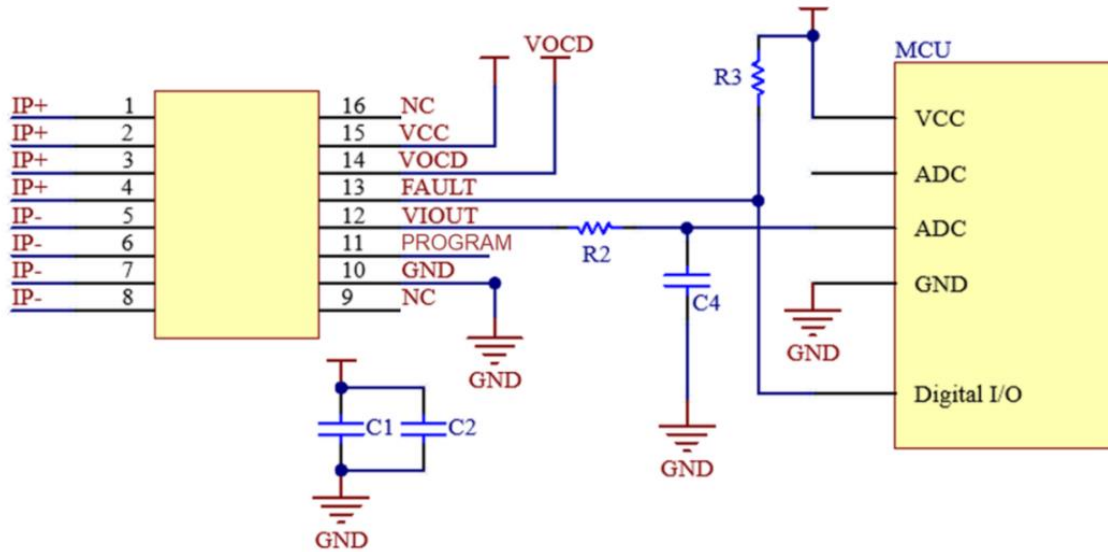

## 12. Examples of OCD function

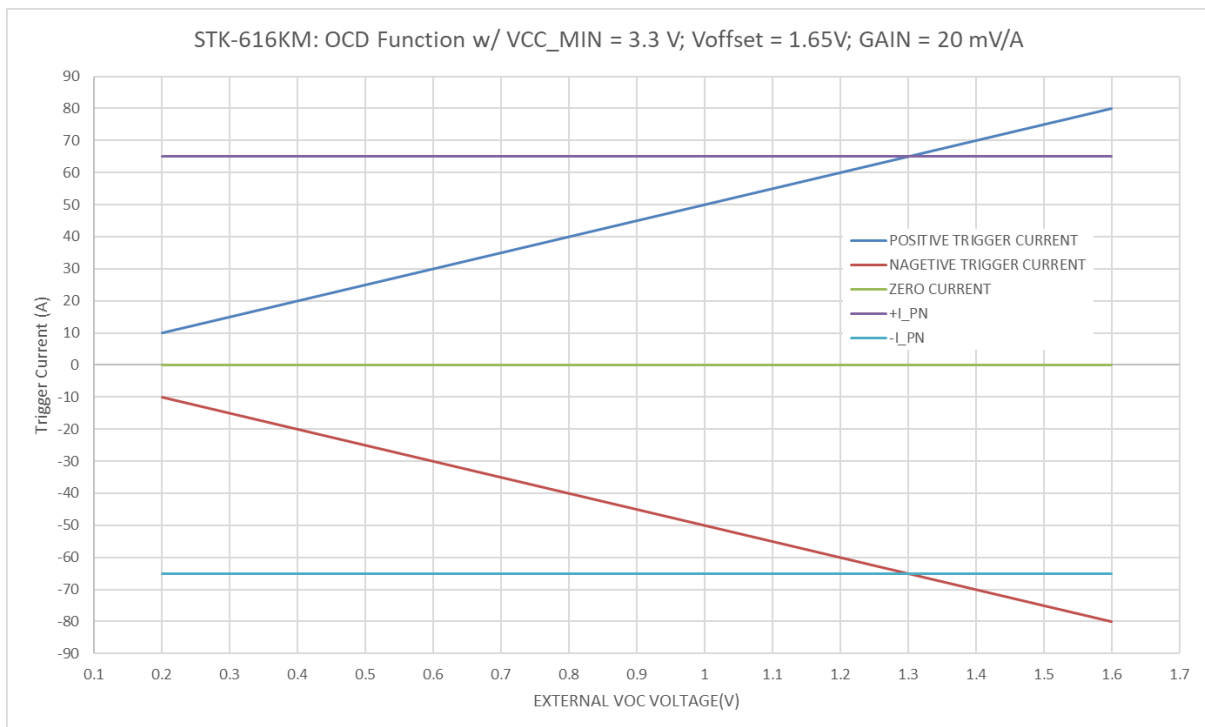

OCD function for STK-616K-65MFB3

### 13. General information on OCD

This section describes the general information on OCD function, the specific functions, which are not listed in the section of “electrical data”, can be defined per request.

Since the trigger voltage is set after the second amplifier, the OCD function supports that the trigger current can be higher than  $I_{pn}$ . The trigger voltage can be defined:

- a)  $V_{ref} = 2.5\text{ V}$ 
  - a)  $0.5\text{ V} \cong VOC \cong V_{cc} - 1.7\text{ V};$
  - b) Trigger voltage =  $V_{ref} \pm VOC;$
  - c) Trigger current =  $(V_{ref} \pm VOC - V_{off}) / G_{th};$
- b)  $V_{ref} = 1.65\text{ V}$ 
  - a)  $0.3\text{ V} \cong VOC \cong V_{cc} - 1.7\text{ V};$
  - b) Trigger voltage =  $V_{ref} \pm VOC;$
  - c) Trigger current =  $(V_{ref} \pm VOC - V_{off}) / G_{th}$
- c)  $V_{ref} = 0.5\text{ V}$ 
  - a)  $0.2\text{ V} \cong VOC \cong 0.5\text{ V};$
  - b) Trigger voltage =  $V_{ref} + 8 \cdot VOC;$
  - c) Trigger current =  $(V_{ref} + VOC - V_{off}) / G_{th}$

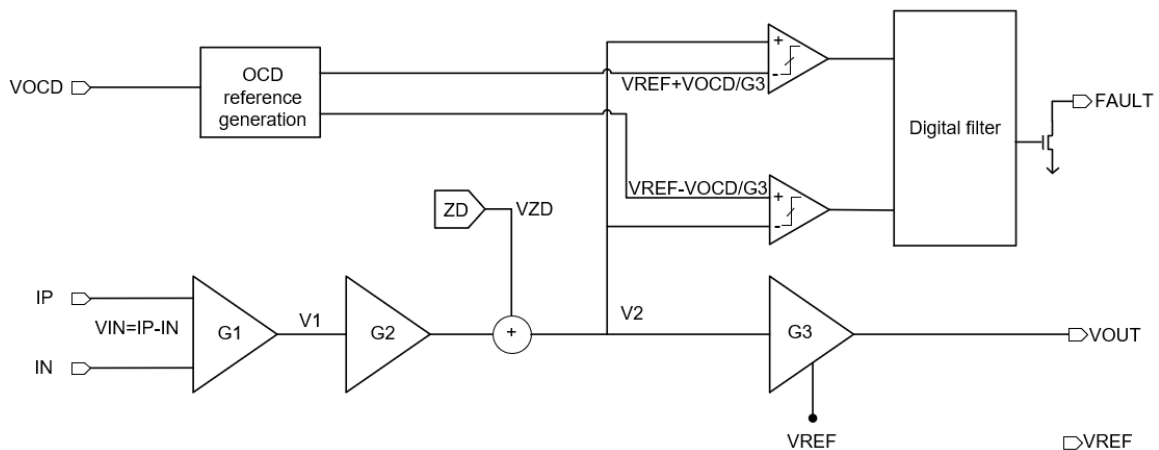

Functional Block Diagram on OCD function when  $V_{ref} = 2.5\text{ V}$

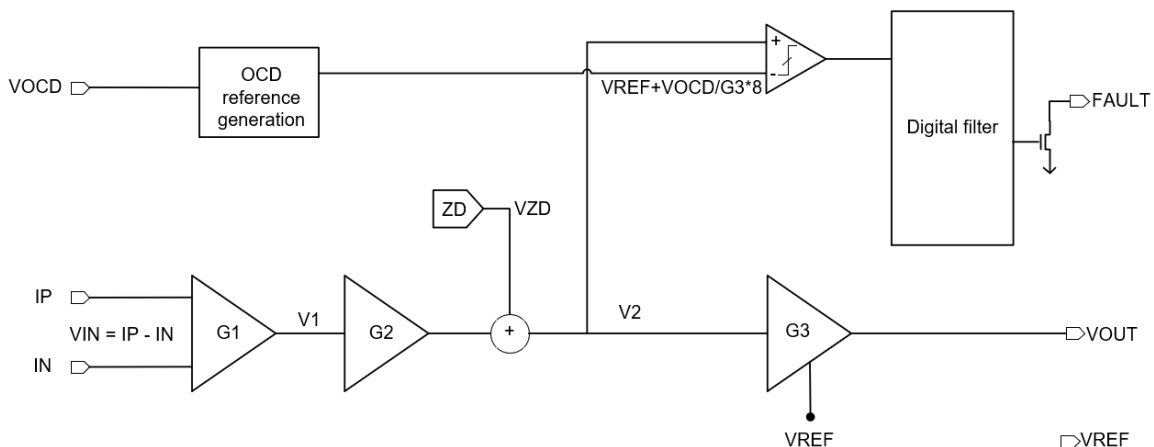

Functional Block Diagram on OCD function when  $V_{ref} = 0.5\text{ V}$

With the above definition, below shows the relationship between trigger voltage and the setting of Vcc, VOC.

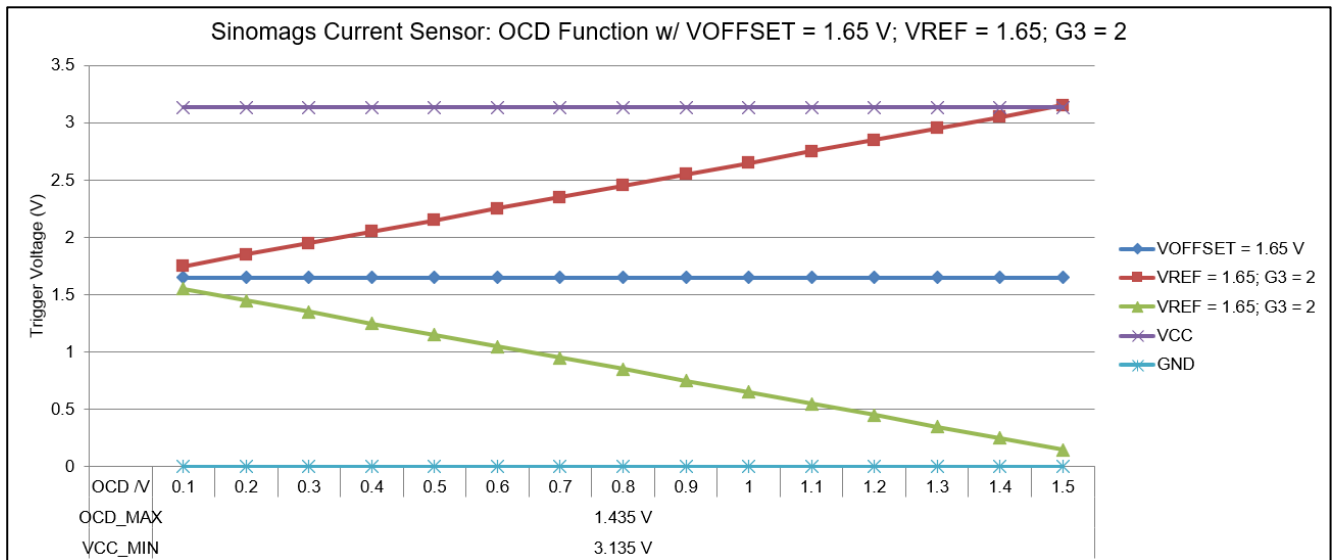
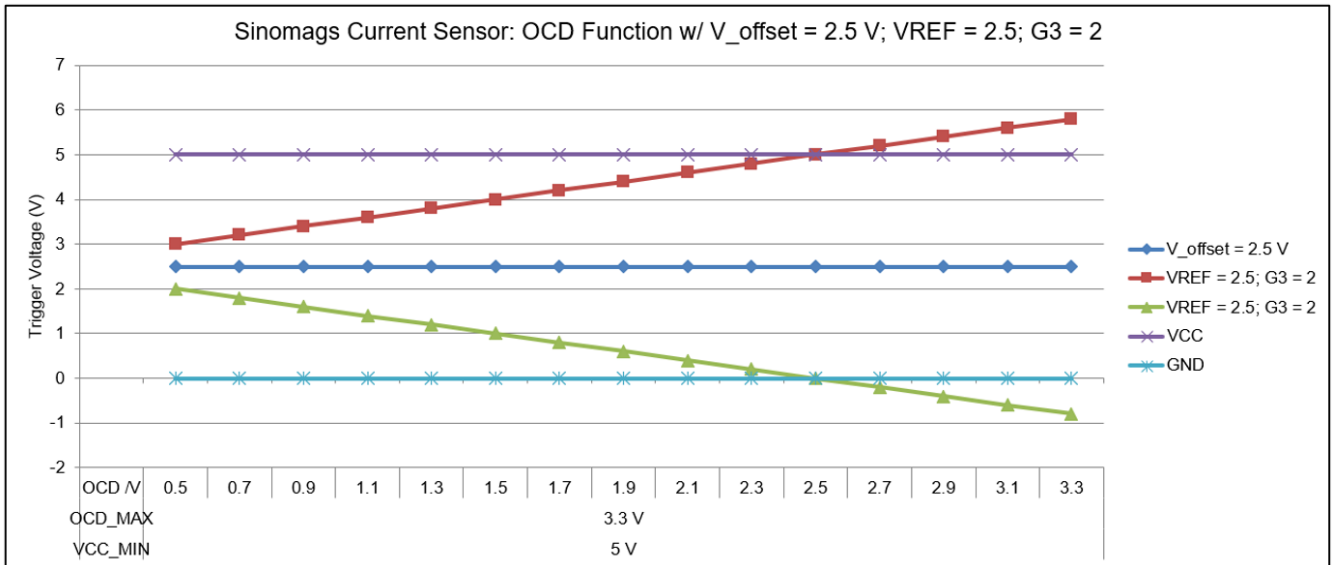

## 14. PACKAGE MATERIALS INFORMATION

### TAPE AND REEL INFORMATION

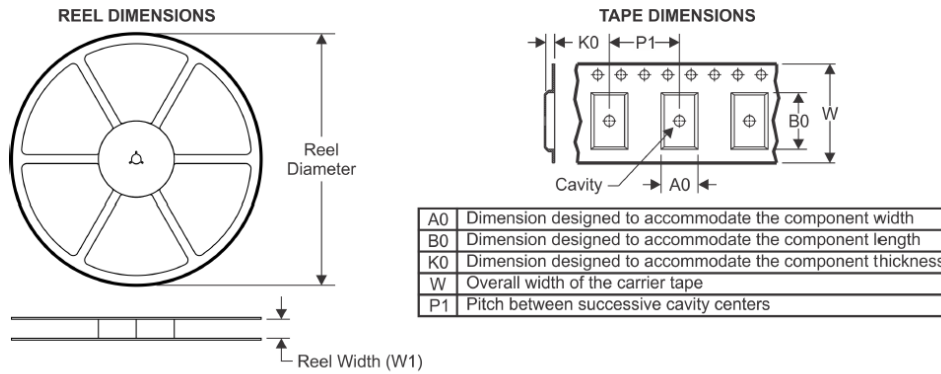

### QUADRANT ASSIGNMENTS FOR PIN 1 ORIENTATION IN TAPE

